

Gas Sampling System

Gas Sampling Manifold Installation Instructions



IsoTube[®]

Gas Sampling System

Gas Sampling Manifold Installation Instructions



Contents

IsoTube® Sampling Manifold

Configurations. 3

IsoTube® Sampling Manifold Mounting Instructions

 A. Cabinet Mount. 4

 B. Horizontal Wall Mount 5

 C. Vertical Wall Mount. 6

Maintenance of the IsoTube® Sampling Manifold. 8

Chassis Assembly Diagram 9

Valve Assembly Diagram 10

Kit Includes:

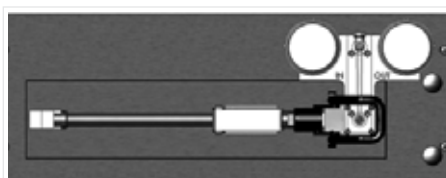

1-IsoTube Gas Sampling Manifold

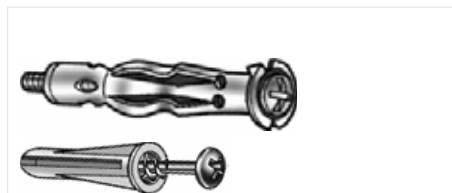

1-Pkg. Wall Anchor/Screw Assortment



4-Extra Rubber, Chuck Washers



2-Wrenches (9/16")



6-Hex Drivers (Sizes: 3/16, 5/32, 9/64, 7/64, 3/32, 1/16)

IsoTube[®] Sampling Manifold Configurations

Before proceeding to the installation instructions, determine the configuration that best matches your setup

IMPORTANT: Sufficient filters and dryers **MUST** be installed before the manifold to ensure a supply of clean, dry gas!

Option #1

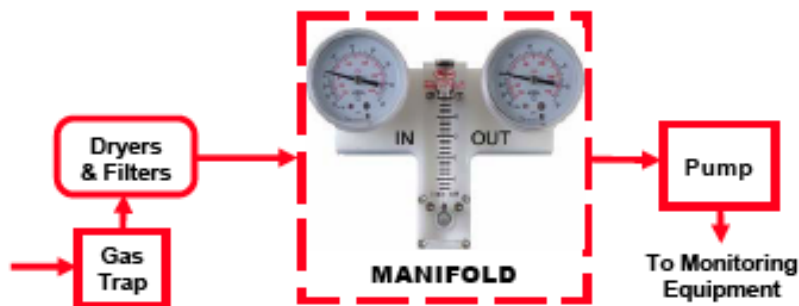

NOTE: This configuration is recommended for those systems in which there is NO SIGNIFICANT PRESSURE DROP between the gas trap and the IsoTube[®] manifold. A continuous flow rate of at least 300cc/min should be maintained (~500cc/min preferred).

Option #2

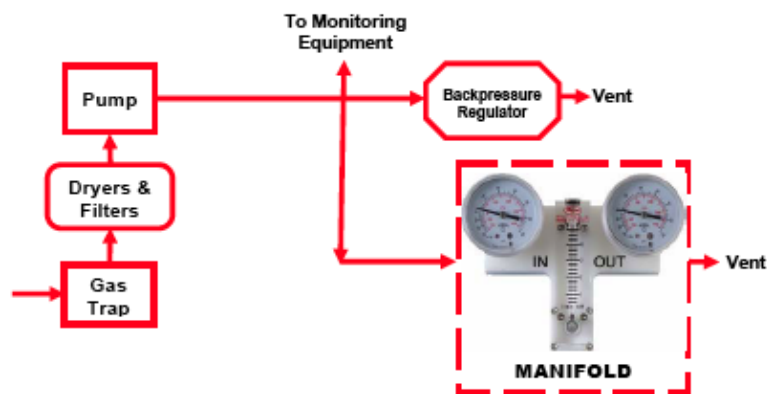

NOTE: This configuration is recommended for those systems in which there IS A SIGNIFICANT PRESSURE DROP between the gas trap and the IsoTube[®] manifold. A continuous flow rate of at least 300cc/min should be maintained (~500cc/min preferred).

IsoTube® Sampling Manifold Mounting Instructions

A. Cabinet Mount (STD 19")

The manifolds are shipped in the horizontal CABINET mounting configuration for use in a standard 19" electronics cabinet. . .for other mounting options see pages 2 (HORIZONTAL WALL MOUNTING), and 3 (VERTICAL WALL MOUNTING).

1. To mount the manifold in a standard 19" electronics cabinet, first remove the front chassis from the box by removing the four panel screws (see below).

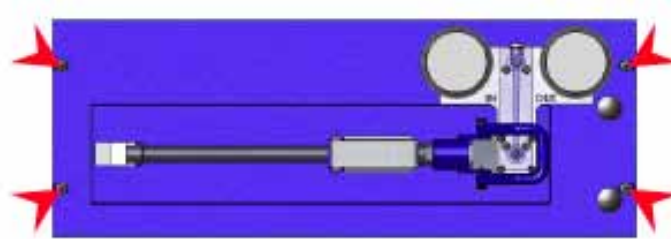

2. **IMPORTANT:** Sufficient filters and dryers **MUST** be installed before the manifold to ensure a supply of clean, dry gas! The fittings on the manifold allow for 1/4" poly line to be plugged directly into them. Connect the gas line to both the manifold and to the gas detector equipment using one of the suggested configurations (see page 1 to determine the configuration that best matches your setup). Introduce the manifold into the line of flow by inserting the supply line into the "IN" side of the manifold, and the outlet line into the "OUT" side of the manifold (see below)...no wrenches are necessary.

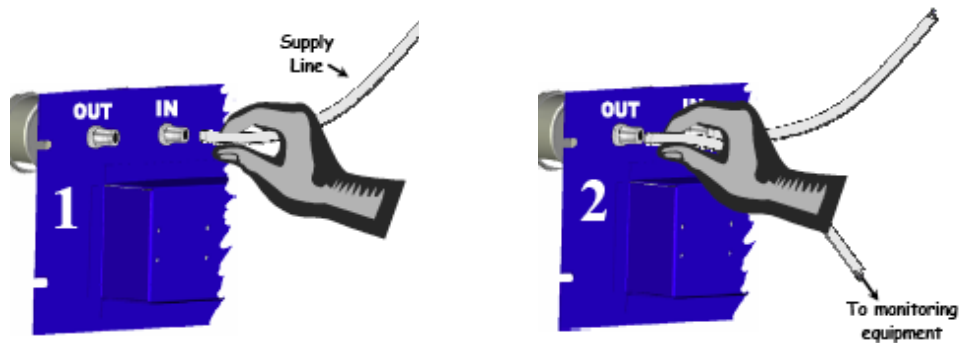

3. Readjust the flow rate to compensate for any resistance caused by the manifold (if necessary). The primary purpose of the flow meter and gauges is to help identify and troubleshoot any leaks or blockages that could develop. Monitoring flow rates and pressures will aid in identifying any malfunctions. Both gauges should read approximately the same when there is flow through either the IsoTube® or the bypass. A problem is indicated if either gauge reads significantly different from the other, or if there is no flow indicated on the flow meter.
4. Attach the chassis to the electronics panel.

B. Horizontal Wall Mount

For mounting horizontally on a wall a few adjustments need to be made.

1. To mount the manifold horizontally ON THE WALL, first remove the front chassis from the box by removing the four panel screws (see right).

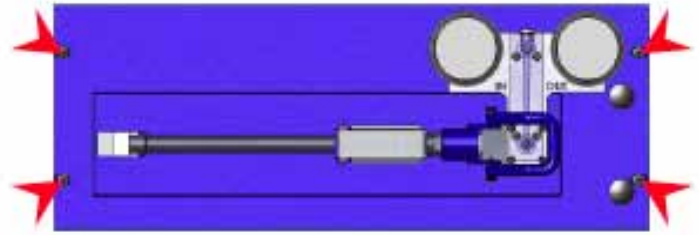

2. Next remove the pipe plugs from the INLET & OUTLET on the sides of the Gauge "T," and also the tube fittings from the back of the "T". Move the tube fittings to the INLET & OUTLET ports on the sides of the "T" (from where the plugs were just removed), and then insert the pipe plugs into the holes in the back of the "T". TEFLON TAPE IS NOT NECESSARY (see below)



3. Next, identify a suitable location to mount the IsoTube® Gas Sampling Manifold (i.e. near the point where the mudgas line enters the building...the manifold should be easily accessible). Mount the empty box onto the wall with the supplied screws/anchors.
4. Re-attach the manifold chassis to the box using the 4 panel screws removed in Step 1.
5. **IMPORTANT: Sufficient filters and dryers MUST be installed before the manifold to ensure a supply of clean, dry gas!** The fittings on the manifold allow for 1/4" poly line to be plugged directly into them. Connect the gas line to both the manifold and to the gas detector equipment using one of the suggested configurations (see page 1 to determine the configuration that best matches your setup). Introduce the manifold into the line of flow by inserting the supply line into the "IN" side of the manifold, and the outlet line into the "OUT" side of the manifold (see below).



6. Readjust the flow rate to compensate for any resistance caused by the manifold (if necessary). The primary purpose of the flow meter and gauges is to help identify and troubleshoot any leaks or blockages that could develop. **Monitoring flow rates and pressures will aid in identifying any malfunctions.** Both gauges should read approximately the same when there is flow through either the IsoTube® or the bypass. A problem is indicated if either gauge reads significantly different from the other, or if there is no flow indicated on the flow meter.

C. Vertical Wall Mount*

*The manifolds are shipped with the "Gauge T" in the horizontal CABINET mounting configuration. To wall mount the manifold VERTICALLY, a few adjustments need to be made...

1. First, remove the manifold chassis from the box by removing the four panel screws (see below).
2. For conversion to vertical mounting, the white "Gauge T" of the manifold containing the gauges and flow-meter must be rotated 90° clockwise (see below).

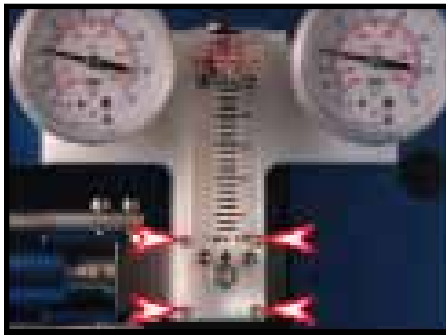
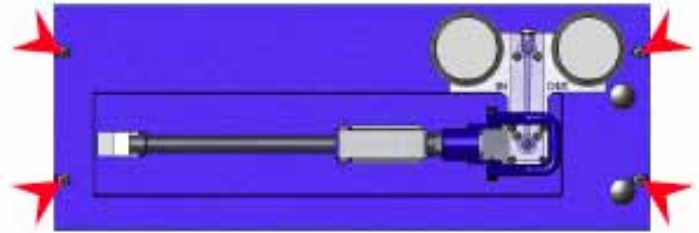

Carefully loosen the 4 hex head screws (indicated) from the white "Gauge T" of the manifold.

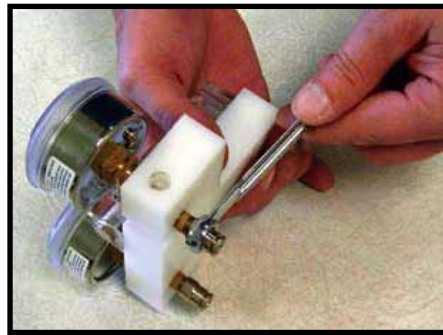

Remove the pipe plugs from the INLET & OUTLET on the sides of the "T"

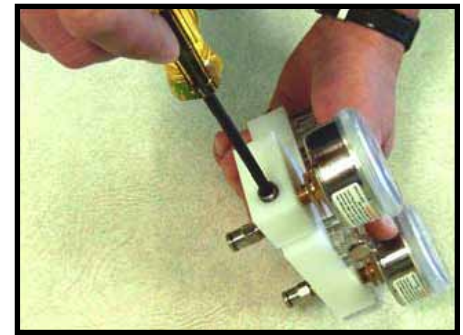

Next, remove the tube fittings from the back of the "T".



Move the tube fittings to the INLET & OUTLET ports on the sides of the "T" (from where the plugs were just removed) and then insert the pipe plugs into the holes in the back of the "T". TEFLON TAPE IS NOT NECESSARY.

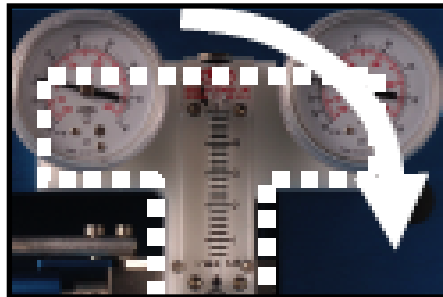

Remove the black plastic hole-plugs, and rotate the "T" 90° clock-wise from its original position. In-vert the 4 hex head screws into their corresponding holes... be sure that the o-rings that make the seal between the "T" and the valve housing do not become dislodged.



Tighten the screws (indicated) until snug, and so that the "base of the "T" is secure against the metal valve housing.

3. Next, identify a suitable location to mount the IsoTube® Gas Sampling Manifold (i.e. near the point where the mudgas line enters the building...the manifold should be easily accessible). Mount the empty box onto the wall with the supplied screws/anchors.
4. Re-attach the manifold chassis to the box using the 4 panel screws removed in Step 1.

5. **IMPORTANT: Sufficient filters and dryers MUST be installed before the manifold to ensure a supply of clean, dry gas!** The fittings on the manifold allow for 1/4" poly line to be plugged directly into them. Connect the gas line to both the manifold and to the gas detector equipment using one of the suggested configurations (**see page 1 to determine the configuration that best matches your setup**). Introduce the manifold into the line of flow by inserting the supply line into the "IN" side of the manifold, and the outlet line into the "OUT" side of the manifold (see below).

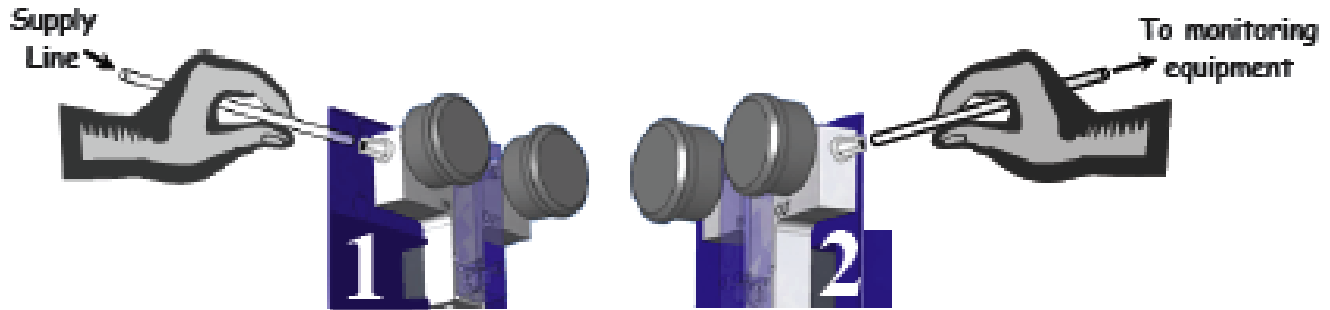

6. Readjust the flow rate to compensate for any resistance caused by the manifold (if necessary). The primary purpose of the flow meter and gauges is to help identify and trouble shoot any leaks or blockages that could develop. **Monitoring flow rates and pressures will aid in identifying any malfunctions. Both gauges should read approximately the same** when there is flow through either the IsoTube[®] or the bypass. A problem is indicated if either gauge reads significantly different from the other, or if there is no flow indicated on the flow meter.

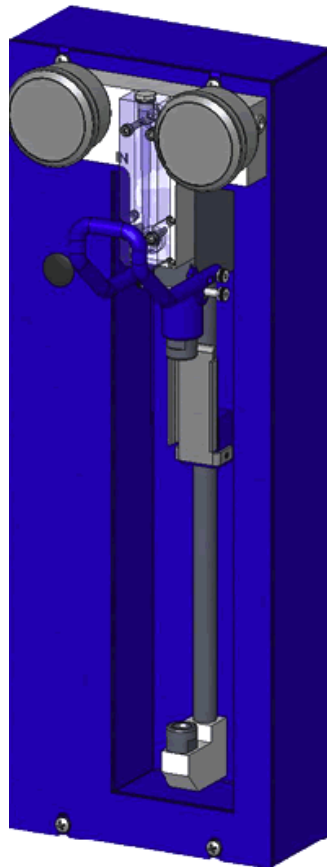

Maintenance of the IsoTube® Sampling Manifold

The only maintenance normally required for the IsoTube® Sampling Manifold is periodic changing of the rubber washers inside of the chucks. The black rubber washers should be examined for wear periodically. It is normal to have metal dust on the washer and this can be wiped off with a soft cloth. When washers are cracked or show signs of wear, they should be replaced. This will require two 9/16" wrenches (included) and a small screwdriver. Spare rubber washers are included along with the mounting kit.

1. Place the one wrench on the base of the valve shaft, and the other wrench on the end cap of the chuck. **NOTE: It is NOT necessary to remove the valve shaft from the metal valve body to change the rubber washer.**

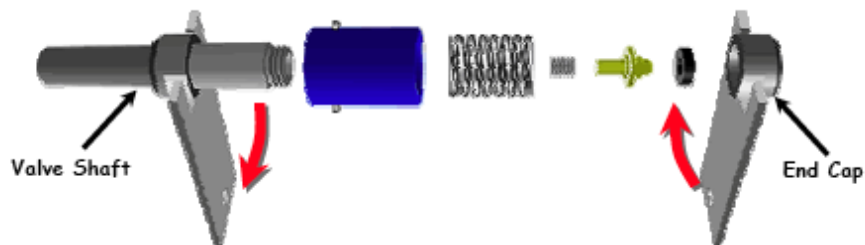

2. Remove the end cap (this is a standard right-hand thread)
3. **CAUTION:** After the end cap has been removed you will find a large spring, A SMALL SPRING, a brass depressor pin and a rubber washer.
4. Use a small screwdriver to push the washer out of the end cap.
5. If the washer is worn or damaged, insert a new washer into the end cap.
6. Reattach the end cap making sure that the brass depressor remains centered and that the tip extends through the center of the rubber washer.
7. If either of the rubber washers show signs of wear, it is best to replace both of them. Repeat the above steps for the lower chuck, and insert the depressor pin through the spring and into the chuck base, then screw on the end cap with the new rubber washer inserted in it.



8. Tighten the end cap until snug...do **not** over-tighten.
9. Double check the chucks to be certain that the depressor pins are properly oriented.

For any problems with IsoTube® Sampling equipment, contact Isotech at (217) 398-3490 or isotubes@isotechlabs.com. Your comments and suggestions for improvements will be appreciated.

Chasis Assembly Diagram

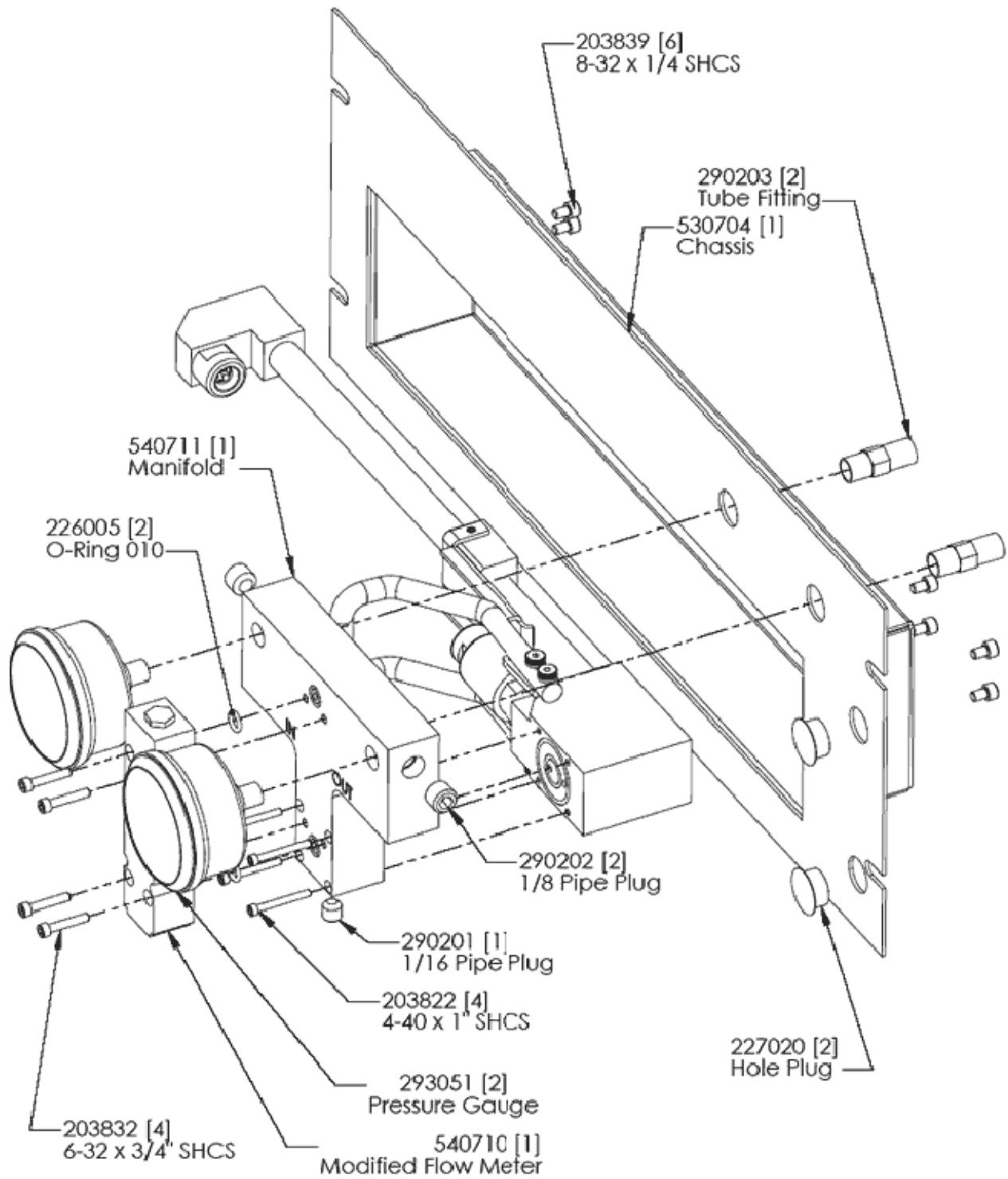

Valve Assembly Diagram

